

CONTINENTAL

**72.0 HP GASOLINE
DUAL FUEL, LPG &
NG OPTIONS**

TM27

**YOUR
HEAVY-DUTY
SOURCE OF
POWER**

Setting industry standards since the turn of the 20th century. Continental offers you a liquid-cooled gasoline engine ranging to 72 horsepower. Continental continues to offer you the only engine within its class, "INDUSTRIAL BY DESIGN."

CONTINENTAL CONSTRUCTION

Continental Engines are designed for worldwide acceptance and are the first metric industrial engine produced in the United States. This heavy-duty source of power offers outstanding reliability and durability for a wide variety of industrial applications.



STANDARD FEATURES

- 4-Cylinder
- Liquid-Cooled, OHV
- Five Main Bearings
- Heavy-Duty, Cast-Iron Block & Crankcase
- High Volume Water Pump
- 63 amp Alternator with Internal Regulator
- SAE #4 Flyball Housing
- High Volume Oil Pump
- Full-Flow Oil Filter
- 85% Parts Interchangeable

WORLDWIDE PARTS & SERVICE

We back our engines with a worldwide service network. Experienced Continental representatives are always ready to meet your needs.



**WISCONSIN
MOTORS, LLC**

CONTINENTAL

72.0 HP GASOLINE DUAL FUEL, LPG & NG OPTIONS

TM27

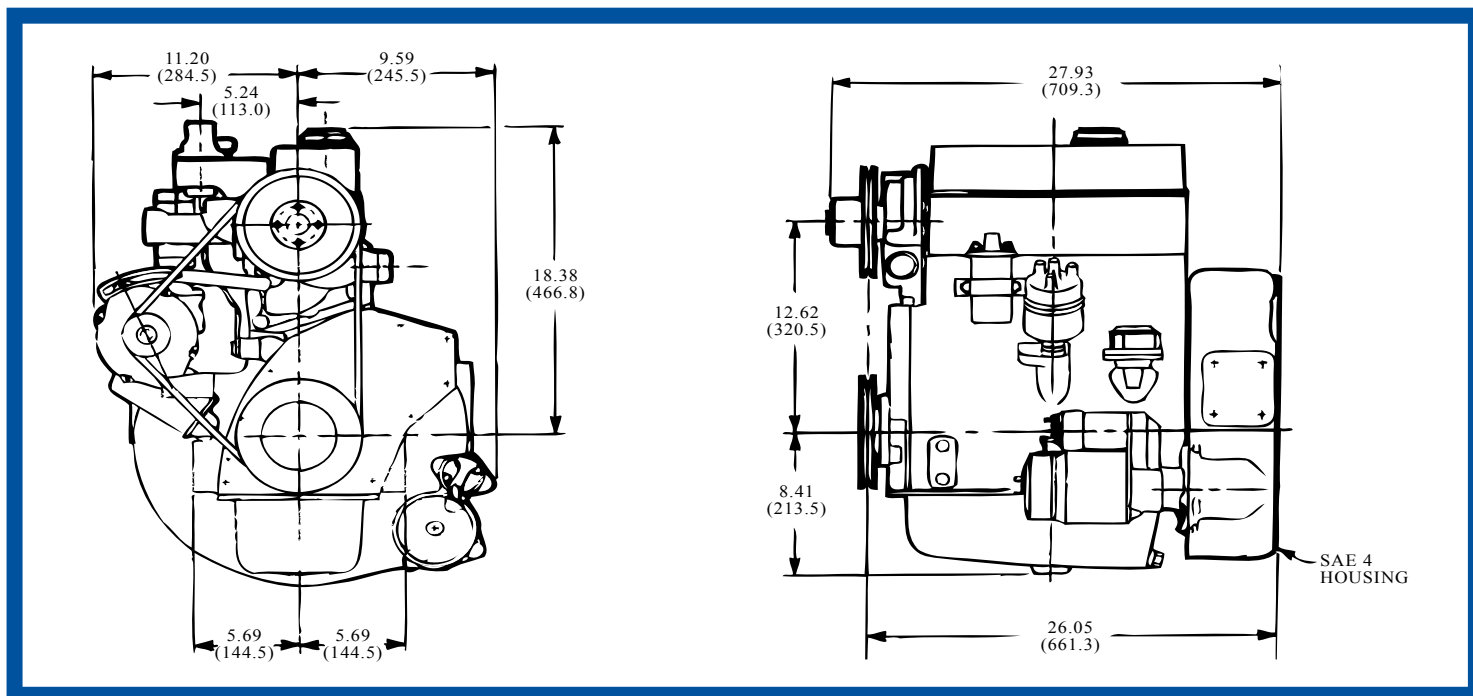

* Net Weight Dry Standard Engine 535 lbs. (242.6 kg)

Bore 3.58 in. (91 mm)
Stroke 4.06 in. (103.2 mm)
Displacement 164.7 cu. in. (2.7 L)

RPM	HP	KW	TORQUE
			Ft. lbs
1500	41.9	31.2	163.0
1800	50.4	37.6	163.3
2000	55.6	41.5	162.2
2400	64.7	48.2	157.3
2600	67.9	50.6	152.3
2800	70.1	52.3	146.1
3000	72.0	53.7	149.1

POWER OUTPUT

Maximum dynamometer net brake horsepower of the basic engine corrected to a pressure reading of 29.3 in. Hg (99 KPA) dry barometer and temperature of 77° F (25° C) when tested in accordance with SAE Test Code J1349. Engine output can be demonstrated within 5% at the factory under standard rating conditions. Power will decrease 3.5% for each 1000 ft. (305 M) above 500 ft. and 1% for each 10° F above standard temperature of 77° F (25° C). For continuous operation, applications should be limited to 80% of power shown.

OPTIONS FOR EVERY NEED

- SAE #3 Bell Housing
- Certified Version for Industrial Applications
- Gas, LPG, Dual Fuel or Natural Gas Configurations
- Several Water Outlet Elbows
- Optional Oil Pan Drain Outlet Locations
- Various Flywheels

* Contact your Continental Representative for Additional Options



**WISCONSIN
MOTORS, LLC**

SALES OFFICE:

2020 Fletcher Creek Dr. • Memphis, TN, 31133

Phone (901) 371-0353 • Toll Free 800-932-2858

www.wisconsinmotors.com